



QUALITEC TECHNOLOGY AWARD

## Super, Smart, and Submersible

Whale receives special mention at the Seatec Qualitec awards.

Qualitec recognizes the most innovative products on display at Seatec, Carrara, Italy. The **Supersub Smart 650** low narrow profile automatic bilge pump was acknowledged for its small profile, easy install design.



(left to right) Brian Maxwell, Whale EU Marine Sales Manager and Federico Parrinello - Meli, Osculati, OEM Sales Manager

Traditionally bilge pump designs are often too large to fit into the typically confined spaces deep down in the bilge or under engines. Whale has solved the problem with the new automatic Supersub Smart 650.

### No separate bilge switch required

- Electric field sensor technology inside

### Easy install

- Outlet port and pump head rotate to suit your installation
- Extra long wires (caulked and tinned)

### Fits in confined spaces

- Low narrow profile 60mm (2 1/2")

### Easy clean

- Removable strainer

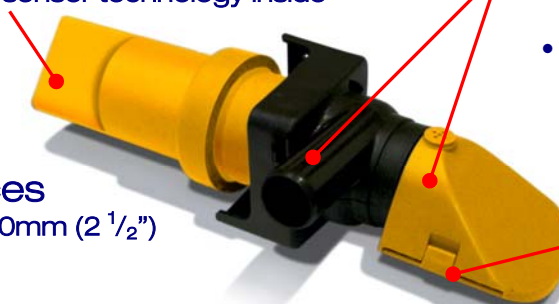

Qualitec Award 2009- Menzione Speciale

# PRESS RELEASE

Munster Simms Engineering Ltd. Old Belfast Road, Bangor, BT19 1LT, N.Ireland  
tel: +44 (0)28 9127 0531 fax: +44 (0)28 91466421 info@whalepumps.com whalepumps.com



## Low Profile

Supersub Smart 650's unique low profile narrow footprint means that the pump can be installed in those hard to reach areas for bilge water pump out.

### Typical Installations

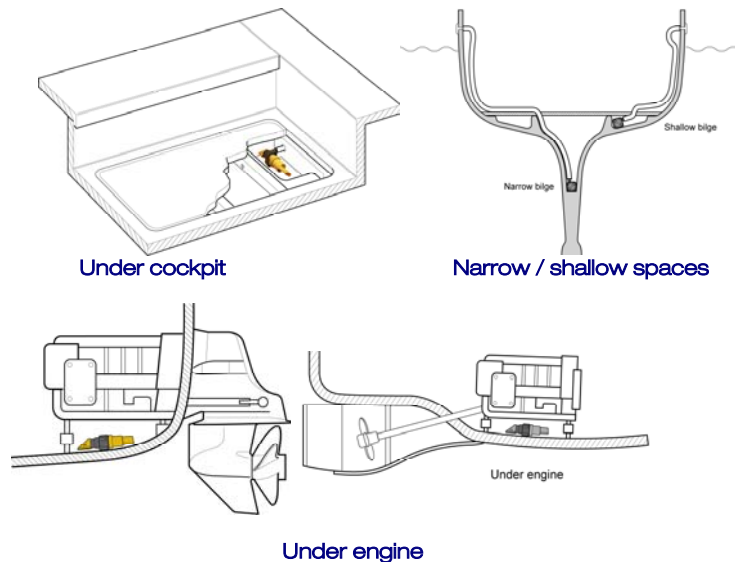

Whale Supersub Smart 650 is quick and easy to install, with rotatable parts and extra long wires. The sensor switch technology simplifies wiring.



### No need for a separate bilge switch.

The unique low profile pump incorporates the latest electric field sensor technology.

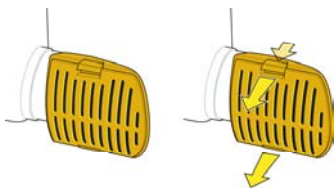

### Easy to maintain

The pump is easily maintained with a removable strainer for easy cleaning.

**Whale** is a key player in the leisure marine industry specialising in the design and manufacture of water and waste products. The range includes manual and electric freshwater, bilge and waste pumps, Quick Connect plumbing systems, faucets, showers and accessories. The company combines innovative products with excellent customer service to supply the world's power and sailboat manufacturers, and has a worldwide distribution to retail network. Whale is an ISO certified company.

To request information on Supersub Smart 650 or the Whale range please contact **Claire McCrea, Whale Marketing Services Manager:-**

Email: [clairemcc@whalepumps.com](mailto:clairemcc@whalepumps.com) or telephone: +44 (0)28 9127 6529  
[www.whalepumps.com](http://www.whalepumps.com)